

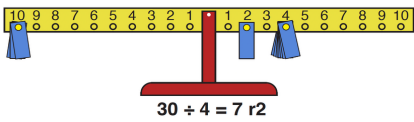



Most recent update: April 7, 2026

RightStart™ Mathematics

Corrections and Updates for Grade 5 Lessons and Worksheets, second edition

LESSON/WORKSHEET		CHANGE DATE	CORRECTION OR UPDATE
Lesson 7		04/18/2018	The Quotient and Remainder game instructions should read: Place the dividend card, the multiplication card, first in the row, as shown below."
Lesson 7		06/02/2025	<p>On the second page, in the Remainders on the math balance paragraph, the third sentence should read: Then put weights on the 4-peg until it is too many, then remove one. [seven] The graphic and label are also changed as shown here. Finally, an explanation has been added:</p> <p>Weights may be hung on both the front and back of the math balance arm.</p> 
Lesson 8		11/11/2020	On the second page under the Summarize heading, the second sentence should read, "... the remainder of the sum will equal the sum of the remainders of the two original numbers" rather than "... the remainder of the sum will add up to the remainders of the two original numbers."
Lesson 9		11/11/2020	On the first page in the middle of the page, it should read "What is 40 divided by 2? [20] Write the 2 in the tens place as shown below" rather than "write the 2 in the hundreds place..."
Lesson 13		10/02/2024	On the second page, right above the Worksheet 4 heading, the check number for 240 should be (6) , not (0).
Lesson 16	Worksheet 6	01/07/2019	The second paragraph of Information on the worksheet (and written in the lesson) should read "In the expression 3^2 , the exponent 2 means that the number 3 is multiplied two times. " See attached pdf for the worksheet.
Lesson 18		10/09/2023	On the second page, we added an explanation for the solution for Problem 4: For the first solution, $72 + 32$, see the seven beads on the seven rows, then add the three beads on the three rows. For the second solution, $10 \times 3 + 7 \times 4$, mentally combine the first three rows, removing the gap between the seven beads and the three beads. This will then show 10×3. Then the remaining seven beads on the four rows create the additional 7×4.
Lesson 20		04/07/2026	The paragraphs on Multiplying by 10 and Dividing by 10 have been changed to be more clear and more accurate. See attached pdf .
Lesson 24		10/06/2020	On the second page after the second set of abacuses, it should read "Next tell her... add 15 hundredths and 6 hundredths ", not 6 hundreds.

Lesson 36		11/14/2025	When measuring the width of the Basic cards, the numbers will vary depending on which version of the card decks are being used. See attached pdf for possible measurements.
Lesson 40	Worksheet 29	01/07/2019	In the warm-up, the second sentence referring to dividing by the same number has been removed. See attached pdf .
Lesson 41		12/29/2017	On the second page in the middle of the page at the end of the paragraph, it should read "What is the expression after multiplying by 10 ? [7.5/5]" It previously read 100.
Lesson 46		08/22/2023 03/27/2019	In the first paragraph, Introducing long division, the second set of graphics, a explanation was added on the right: In this example of $195 \div 21$, the quotient, 9, is provided here because the focus is on writing the product of 21×9 , not finding how many 21s are in 195. Finding the quotient will be taught in a future lesson. Under the section Finding Remainders, the last example should read $26 \overline{)210}$ with 8 as the quotient and 2 as the remainder , not 7 as the quotient and 28 as the remainder.
Lesson 51		10/10/2022	On the second page, the the explanation should read "... divide 5 by 12 on the calculator ..." rather than "... divide 12 by 5 on the calculator ..."
Lesson 54	Worksheet 42-B	12/29/2017	The last equation in the "<, >, or =" section should read $87 \times 32.5 \div 87$, not $87 \div 32.5 \times 87$ as printed. Answer is the lesson book is correct.
Lesson 57	Worksheet 45	01/05/2026	In the middle of the worksheet, there is a question about the last time a year was a perfect square. It has been changed: The year 2025 was the last time that a year was a perfect square. The number 2025 is 45^2 . What year will be the next perfect square? The answer, found at the top of the second page in the lesson book, is $45^2 + 45 + 46 = 2025 + 91 = 2116$.
Lesson 57		03/17/2019	On the second page, at the bottom of the "Squaring a sum" paragraph, the equation should read $(3 + 2)^2 = 3^2 + 2^2 + 2 \times (3 \times 2)$, not $(3 + 2)^2 = 3^2 + 2^2 + 2 \times (3 + 2)$.
Lesson 58		01/13/2025	On the second page, at the end of the first paragraph under Square roots on a calculator, the answer for the square root of 31 is close to 5.6 , not 5.5.
Lesson 60	Worksheet 48	12/28/2022	Problem 1 should ask for measurements in centimeters , not tenths of a centimeter. Problem 2 should ask for measurements in hundredths of a centimeter for Figure 4, not tenth of a centimeter. See attached PDF . In the lesson, the solutions for Problem 2, Figure 4 Side of C should be 3.30 cm , not 3.3 cm.
Lesson 60		07/02/2024	A note has been added next to the answers for Problem 2, Figure 4: The actual calculation for $\sqrt{10.73}$ is 3.27566787083. Although many will round the answer to 3.28 cm, measuring 3.28 cm precisely with the provided tools is not possible. Therefore, if the child records 3.28 cm as the Side of C, it is correct. Then, the measurement of 3.3 cm, given rounding, is "the same" as the calculated measurement.

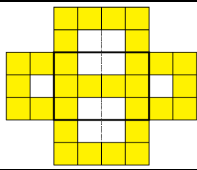
Lesson 61		06/22/2023	The three answers Problem 1, Figure C, are wrong. Correct answers are highlighted.	<table border="1"> <thead> <tr> <th rowspan="2"></th> <th colspan="3">Figure B</th> <th colspan="3">Figure C</th> </tr> <tr> <th>1 small square</th> <th>2 small squares</th> <th>Large square</th> <th>1 small square</th> <th>2 small squares</th> <th>Large square</th> </tr> </thead> <tbody> <tr> <td>Area in </td> <td>4</td> <td>8</td> <td>8</td> <td>8</td> <td>16</td> <td>16</td> </tr> <tr> <td>Side in cm</td> <td>5</td> <td></td> <td>7</td> <td>7</td> <td></td> <td>10</td> </tr> <tr> <td>Area in cm²</td> <td>25</td> <td>50</td> <td>49</td> <td>49</td> <td>98</td> <td>100</td> </tr> <tr> <td>Side in mm</td> <td>50</td> <td></td> <td>70</td> <td>70</td> <td></td> <td>100</td> </tr> <tr> <td>Area in mm²</td> <td>2500</td> <td>5000</td> <td>4900</td> <td>4900</td> <td>9,800</td> <td>10,000</td> </tr> <tr> <td>Side in in.</td> <td>2</td> <td></td> <td>2.8</td> <td>2.8</td> <td></td> <td>3.9</td> </tr> <tr> <td>Area in in²</td> <td>4</td> <td>8</td> <td>7.8</td> <td>7.8</td> <td>15.6</td> <td>15.2</td> </tr> </tbody> </table>		Figure B			Figure C			1 small square	2 small squares	Large square	1 small square	2 small squares	Large square	Area in 	4	8	8	8	16	16	Side in cm	5		7	7		10	Area in cm ²	25	50	49	49	98	100	Side in mm	50		70	70		100	Area in mm ²	2500	5000	4900	4900	9,800	10,000	Side in in.	2		2.8	2.8		3.9	Area in in ²	4	8	7.8	7.8	15.6	15.2
	Figure B			Figure C																																																														
	1 small square	2 small squares	Large square	1 small square	2 small squares	Large square																																																												
Area in 	4	8	8	8	16	16																																																												
Side in cm	5		7	7		10																																																												
Area in cm ²	25	50	49	49	98	100																																																												
Side in mm	50		70	70		100																																																												
Area in mm ²	2500	5000	4900	4900	9,800	10,000																																																												
Side in in.	2		2.8	2.8		3.9																																																												
Area in in ²	4	8	7.8	7.8	15.6	15.2																																																												
Lesson 64		04/18/2018	The answer for the last question in the Warm up should be "multiply a side by itself or $A = s^2$," not "multiply a side by 4 or $A = s^2$."																																																															
Lesson 64	Worksheet 52	04/11/2018	In the last chart on the page, the middle heading should read Boundary Pairs – 1 , not Boundary Pairs. See attached pdf .																																																															
Lesson 66	Worksheet 54	04/18/2018	Questions should read "Are the formulas for finding... all correct?," not ""Are the formulas for finding... are correct?" See attached pdf .																																																															
Lesson 67		01/07/2019	The height measurements for the second and third triangles in Problem 2 should be 1.2, not 1.0. This changes the area to 0.78 in ² , not 0.7 in ² . See attached pdf for the second page of the lesson.																																																															
Lesson 67	Worksheet 55	01/07/2019	The instructions and figures have changed slightly. See attached pdf .																																																															
Lesson 70		03/01/2023	On page two, the formula for the bottom triangle should read " $A(\text{bottom}) = \frac{1}{2}w_2h$ " not " $A(\text{top}) = \frac{1}{2}w_2h$."																																																															
Lesson 70	Worksheet 58	01/07/2019	The second sentence in Question 1 should read, " Use a tangram to draw the height for both triangles using the horizontal lines as the base ." See attached pdf .																																																															
Lesson 73		05/04/2021	On the second page under Finding Volume, the second paragraph should ask the child to make three more identical arrays, not four more.																																																															
Lesson 74		02/16/2025	On the top of the second page, the explanation should reference that ten square panels will be missing, not two panels. Also added is a diagram of one way the construction could work.																																																															
Lesson 74		10/05/2025	On the top of the second page, the second paragraph should read: Ask: How many times greater is the second prism compared to the first prism? [$24 \div 6 = 4$] How could you imagine the four smaller prisms fitting in the larger prism? [two turned sideways on the bottom row and two more on the upper row]																																																															
Lesson 75		02/15/2018	On the second page, the calculation for the triangular prism should read $\frac{1}{2} \times 2.5 \times 2.1$ for the base , calculating the volume at 19.7 cm³ .																																																															
Lesson 76		04/11/2018	On the second page, last paragraph under the Problem 4 heading, the answer should read 1,000,000,000 , not 1,000,000.000.																																																															
Lesson 78		08/22/2023	The answers for the first page of the worksheet, finding the area of the trapezoid, should have an answer of 21.6 m ² , not 21.6 m.																																																															

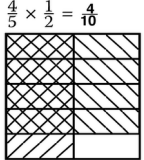
Lesson 91		04/18/2018	First answer for the warm up should be $7 \frac{11}{9} = 8 \frac{2}{9}$, not $8 \frac{2}{5}$.
Lesson 91		10/10/2022	On the second page, at the end of the second paragraph under Finding more multiples, it should read "Try it for 8 and 6: Is 16 a multiple of 6? [no] Is 24 a multiple of 6? [yes] So a common multiple of 8 and 6 is 24." The next paragraph should read "Starting with 9, is 9 a multiple of 7? [no] Is 18 a multiple of 7? [no] Continue until you get to 63. Ask: Is 63 a multiple of 7? [yes] The first common multiple of 9 and 7 is 63."
Lesson 94		04/18/2018	Answer for the third Warm Up problem should be 1 $\frac{17}{30}$.
Lesson 99		12/15/2019	The graphic for the fourth equation is incorrect. Here is the corrected answer. 
Lesson 106		01/07/2019	The answers for the previous day's worksheets has an incorrect answer (although it is right for Lesson 105). The third expression in the second column, $5/6 \div 4/6$, should be $5/4$, not $4/3$.
Lesson 116		06/03/2020	On the second page, for possibility 3 as part of Problem 2, add the clarifier that the one-way street goes south . For possibility 4, add the clarifier that the one-way streets go south and go east . Answers are NS NE WE WS.
Lesson 117		10/06/2020	An explanation was added across from the six combinations of tiles: Some children may need encouragement to approach the combinations systematically. For example, if blue is the first tile, what are the other possibilities? If the red tile is the first tile, where could the blue and yellow tiles go? A second explanation was added across from the question about the number of possibilities for the first position: The first position is the first tile in the sequence, the second position is the middle tile, and and the third position is the last tile.
Lesson 117	Worksheet 98	10/06/2020	Problem 3 has been changed slightly. It now reads "A unicycling relay team has four members either male or female . The team captain decides the order that they race. How many possibilities are there?"
Lesson 120		03/26/2019	The warm up has the child divide 48 by 8 then 6 and the lesson gives the answer for dividing by 48 by 6 then 8. The lesson book should read 48: 8) 17418.24 is 2177.28 , not 2903.24, then 6) 2177.28 is 362.88 which is correct.
Lesson 125		10/06/2020	A partial product is in error. It should read 4029120 , not 4929120. $\begin{array}{r} 2014.56 \text{ (0)} \\ \times 24 \text{ (6)} \\ \hline 805824 \\ 4029120 \\ \hline 48349.44 \text{ (0)} \end{array}$
Lesson 131		04/18/2018	Last question in the conclusion should read: What is 20 millimeters divided by 1 centimeter? [2], not What is 20 millimeters divided by 10 centimeters? [2]
Lesson 134	Worksheet 115	04/18/2018	Information at the top of the page, conversion for km needs to read: 1 km = 1000 m , not 1000 cm. See attached pdf .

Lesson 134	Worksheet 115	08/01/2021	The last question in Problem 3 should read: Round your answer to one decimal place , not one decimal point.
Lesson 136		10/01/2020	On the second page in the middle of the page below the equation $t = 1 \text{ hr}/200 \text{ km} \times 282 \text{ km} = 1.41 \text{ hr}$, it uses dimensional analysis to change .41 hours, not .42, to minutes. The next equation should read .41 hr $\times 60 \text{ min}/1 \text{ hr} = \mathbf{24.6}$ min, not .42 hr $\times 60 \text{ min}/1 \text{ hr} = 25.2 \text{ min}$.
Lesson 136		12/15/2019	On the top of the second page, after the third word problem, the following three paragraphs are added. Ask him to identify what he knows [distance and rate] and what he is looking for. [time] Refer to the previously written formula, rate = distance/time and write: time = distance/rate. Say: This is another way we could write this relationship. Using this, solve the problem. Solution is below. An explanation was also added: Sometimes putting in a "simple" number, like $3 = 6/2$ in place of $r = d/t$, helps identify other ways to write the equation, such as $2 = 6/3$ or $t = d/r$.
Lesson 137	Worksheet 118	12/15/2019	The dimensions for the carton have been changed to 9.7 cm \times 9.5 cm \times 19.2 cm , not 9.3 cm \times 9.3 cm \times 18.7 cm. The volume of the carton is 1769 cm³ , not 1617 cm ³ .
Lesson 139		04/18/2018	Answer for Worksheet 120-A, under the <, >, or = section, 45 days < 2 months.
Lesson 142		07/24/2024	On the second page, third paragraph under the Follow-up Question heading, the third question should read "What are six names for a square? [rhombus, rectangle, kite , parallelogram, quadrilateral, and polygon]" not five names for a square with the omission of "kite."
Lesson 142	Worksheet 123	04/18/2018	Second to last question and answer for Worksheet 123 should read: What is the name of a quadrilateral with only two sides parallel ? Answer trapezoid is correct. See attached pdf .
Lesson 145		07/02/2024	In the warm up, the first answer should be [90°, 360 \div 4], not [90°, 360 \div 90].
Lesson 145		09/01/2025	The older Safe-T Compass is being replaced by the newer Slide N' Measure Compass. See the instructions for both compasses with the attached pdf .
Lesson 146		01/19/2024	On the second page, the Enrichment question should read "What are two methods you can use to find the area in the triangle surrounding the square?", not surrounded by the square.
Lesson 150	Worksheet 130-1	01/07/2019	Question 22, 151.89×8.3 should be 1260.687 , not 1260.678.
Lesson 150	Worksheet 130-3	12/16/2019	Question 74 has been changed to "How many faces does a hexagonal prism have?" Answer is 8 , not 6.
Lesson 150	Worksheet 130-4	11/16/2020	On the top of page 301, it should say to plot point <i>D</i> to make figure <i>ABCD</i> a rectangle , not a square.

Name: _____

Date: _____

Warm-Up

Divide. Use check numbers to check your answers.

$$4 \overline{) 98765}$$

$$6 \overline{) 98765}$$

$$8 \overline{) 98765}$$

INFORMATION: *Exponents* are a shortcut way of writing a number multiplied by itself a number of times. The exponent is the small number written above the line.

In the expression 3^2 , the exponent 2 means that the number 3 is multiplied *two* times. It means 3×3 . We usually read it as 3 *squared*. In the same way, 4^2 means 4×4 .

Write 5 squared using exponents and using multiplication. _____

Draw 1^2 , 2^2 , 3^2 , 4^2 , and 5^2 squares on the grid below. Label them and find the values.

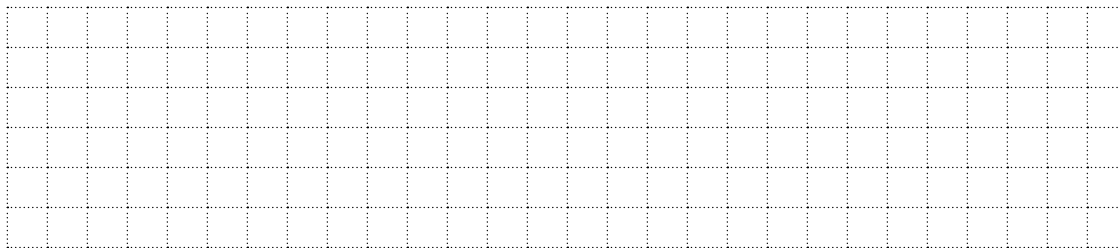

On the multiplication table, evaluate and circle 1^2 , 2^2 , 3^2 , 4^2 , 5^2 , 6^2 , 7^2 , 8^2 , 9^2 , and 10^2 .

1	2	3	4	5	6	7	8	9	10
2	4	6	8	10	12	14	16	18	20
3	6	9	12	15	18	21	24	27	30
4	8	12	16	20	24	28	32	36	40
5	10	15	20	25	30	35	40	45	50
6	12	18	24	30	36	42	48	54	60
7	14	21	28	35	42	49	56	63	70
8	16	24	32	40	48	56	64	72	80
9	18	27	36	45	54	63	72	81	90
10	20	30	40	50	60	70	80	90	100

Evaluate the following expressions.

$$(5^2 - 2^2) \div (3 + 4) \text{ _____}$$

$$(3 + 1)^2 - (4 + 6) \text{ _____}$$

$$[10^2 \times (1 + 4)] \div 2 \text{ _____}$$

$$\frac{1}{2} \times 2^2 + \frac{1}{2} \times 4^2 \text{ _____}$$

$$[(10^2 - 50) - (40 + 8)]^2 \text{ _____}$$

$$[(5^2 - 4^2) - (5 - 3)^2] + 1^2 \text{ _____}$$

LESSON 20: MULTIPLYING AND DIVIDING BY TENS

OBJECTIVES:

1. To realize the decimal point indicates the ones place
2. To experience multiplying and dividing by 10 on a calculator

MATERIALS:

1. Worksheet 10, Multiplying and Dividing by Tens
2. Casio SL-450S calculators
3. *Math Card Games*, D16
4. Math journals

ACTIVITIES FOR TEACHING:

Warm-up. Distribute the worksheets to the children. Tell them to do just the warm-up problems. Solutions are below and on the right.

$$(8 \times 10^2) + (4 \times 10) = \underline{840}$$

$$(8 \times 10^2) \times (4 \times 10^2) = \underline{320,000}$$

$$8 + 10^2 \times 4 + 10^2 = \underline{508}$$

Multiplying by 10. Distribute the calculators. Tell the children to set the calculator to multiply by 10 by using the constant feature. Say: Enter 10 and press $\otimes \otimes$. Then tell them to enter 2 and press \ominus repeatedly. Ask: What happens? [The product is being multiplied by 10 over and over.]

Say: If you press \ominus too many times, an *E*, meaning error, will appear. Clear the error by pressing the \odot button.

Tell them to use the constant feature again by entering 10 and $\otimes \otimes$, then enter 8 and press \ominus repeatedly until the display says 80,000,000. Ask: What punctuation is used to separate the digits? [apostrophes and decimal point] What do the apostrophes group? [thousands and millions] Say: The decimal point tells where the ones place is; it is always placed right after the ones digit. In any number, the decimal point separates the whole part of the number from the part less than one.

Tell them to enter 45. Ask: Did you notice the decimal point after the 5? Is 5 the digit in the ones place? [yes]

Dividing by 10. Now tell the children to set their calculator to divide by 10. Do this entering 10 and pressing $\oslash \oslash$.

Tell them to enter 8000 and to think about what will happen. Then press \ominus , and read the display. [800] Tell them to repeat it two more times. [80, 8] Tell them to do it again. [0.8] Repeat two more times. [0.08 and 0.008]

Worksheet 10. Tell the children to complete the worksheet. The solutions are on the next page.

EXPLANATIONS:

270 (0)
× 4
1080 (0)
× 7
4)7560 (0)
7)1890 (0)
270

On some calculators, an *e* indicates exponent.

Some calculators use commas and omit the decimal point for numbers greater than one.

LESSON 36: MULTIPLYING TENTHS BY A WHOLE NUMBER

OBJECTIVES:

1. To review measuring in tenths
2. To introduce multiplying tenths

MATERIALS:

1. Warm-up Practice 1, found after the math journal in the children's worksheets
2. Five basic number cards per child
3. Five Corners™ cards per child
4. 4-in-1 rulers
5. Worksheet 25, Multiplying Tenths by a Whole Number

ACTIVITIES FOR TEACHING:

Warm-up. Distribute the warm-up practice sheets. Tell the children to complete only the first multivide. Solutions are on the right.

Measuring the width of cards. Distribute the basic number cards, Corners™ cards, the 4-in-1 rulers, and the worksheets. Tell the children to measure the width of one basic number card to the nearest tenth of a centimeter. [5.7 cm for the rounded-corner cards (or 5.4 cm for the sharp-corner cards)] See the left figure below.

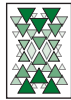

5.7 cm

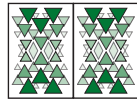

11.4 cm

Ask: How could you calculate the width of two cards? [multiply 5.7 by 2 (or 5.4 by 2)] Tell them to do the calculation. [11.4 cm for the rounded-corner cards (or 10.8 for the sharp-corner cards)] Then tell them to lay two cards side by side and measure them. See the right figure above. Ask: Did your measurements agree with your calculations?

Worksheet 25, Problem 1. Ask the children to read and complete the first problem, which is a continuation of the above activity. The solutions are below.

Number of cards	Width calculated	Width measured
1		5.7 cm
2	11.4 cm	11.4 cm
5	28.5 cm	28.5 cm
10	57.0 cm	
18	102.6 cm	
43	245.1 cm	
75	427.5 cm	
100	570.0 cm	

When they have finished, ask them to share their solutions with a neighbor and then the class.

EXPLANATIONS:

Remind the children to use check numbers with each step as they proceed through the multivide.

The divisors chosen may differ from those shown or be used in a different order.

The second multivide on the warm-up practice sheet will be completed in a future lesson.

$$\begin{array}{r}
 11 \quad (2) \\
 \times 63 \quad (0) \\
 \hline
 33 \\
 660 \\
 \hline
 693 \quad (0) \\
 \times 32 \quad (5) \\
 \hline
 1386 \\
 20790 \\
 \hline
 22176 \quad (0) \\
 \times 36 \quad (0) \\
 \hline
 133056 \\
 665280 \\
 \hline
 798336 \quad (0) \\
 \times 18 \quad (0) \\
 \hline
 6386688 \\
 7983360 \\
 \hline
 63: 9 \overline{)14370048} \quad (0) \\
 7 \overline{)1596672} \\
 32: 8 \overline{)228096} \quad (0) \\
 4 \overline{)28512} \\
 36: 6 \overline{)7128} \quad (0) \\
 6 \overline{)1188} \\
 18: 9 \overline{)198} \quad (0) \\
 2 \overline{)22} \\
 \hline
 11
 \end{array}$$

Here are the measurements for the sharp-corner cards.

Number of cards	Width calculated	Width measured
1		5.4 cm
2	10.8 cm	10.8 cm
5	27.0 cm	27.0 cm
10	54.0 cm	
18	97.2 cm	
43	232.2 cm	
75	405.0 cm	

The very old solid green card decks may measure slightly less.

Name: _____

Date: _____

Warm-Up

Multiply the numbers given. Use check numbers to check your work if you like.

		0	.	8	5	()
		×	2	4	()	
						()

				3	8	()		
			×	0	.	4	9	()
								()

Write the equations shown on the abacuses. Each bead on the abacus represents 0.1.

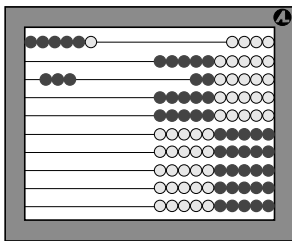

$$\frac{0.6}{0.3} = \underline{\quad}$$

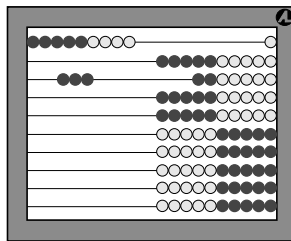

$$\underline{\quad} = \underline{\quad}$$

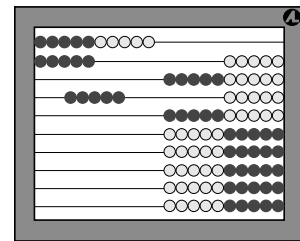

$$\underline{\quad} = \underline{\quad}$$

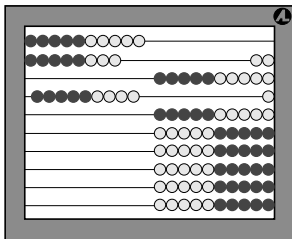

$$\underline{\quad} = \underline{\quad}$$

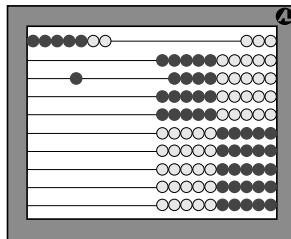

$$\underline{\quad} = \underline{\quad}$$

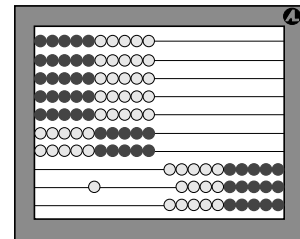

$$\underline{\quad} = \underline{\quad}$$

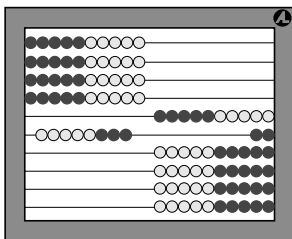

$$\underline{\quad} = \underline{\quad}$$

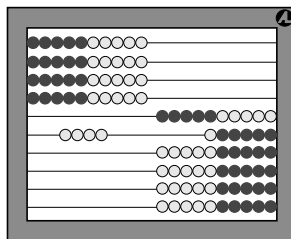

$$\underline{\quad} = \underline{\quad}$$

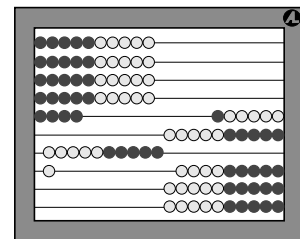

$$\underline{\quad} = \underline{\quad}$$

If each bead in the abacuses above suddenly explodes becoming ten times greater, what happens to your answers? _____

Name: _____

Date: _____

1. For each figure, measure the length of the side of squares in centimeters. Then complete the table.

Figure 1.

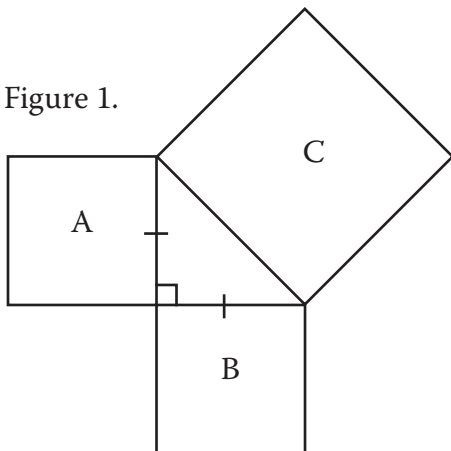

Figure 2.

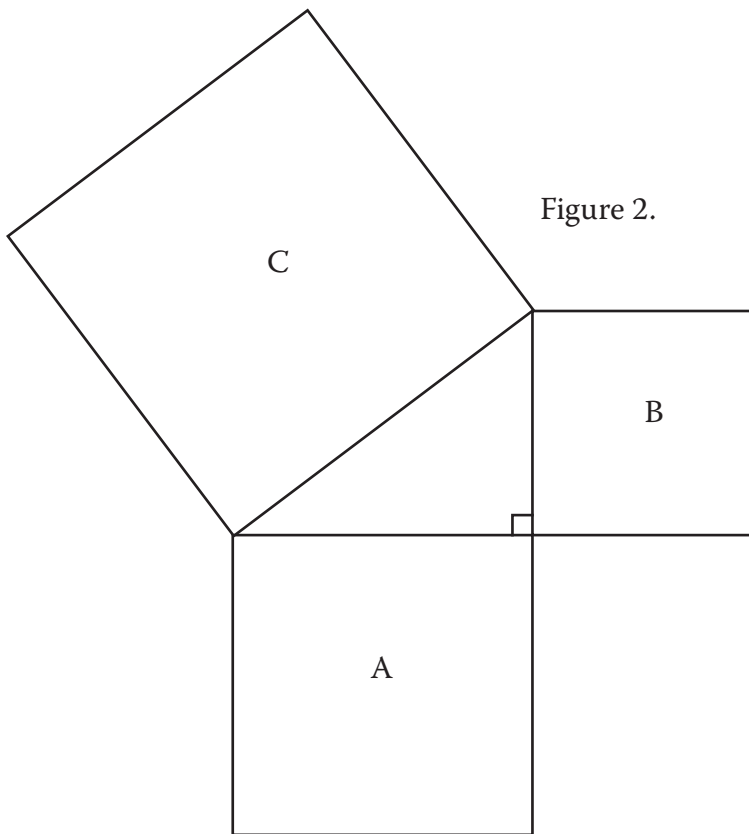

	Figure 1	Figure 2
Side of A		
Side of B		
Side of C	2.83 cm	
Area of A		
Area of B		
Area of C		

In each figure, how does the area of the two smaller squares compare to the area of the larger square?

2. Measure the sides of squares A and B and calculate the side of C. Use millimeters for Figure 3 and hundredths of a centimeter for Figure 4. Fill in the table. Use a calculator to find square roots.

Figure 3.

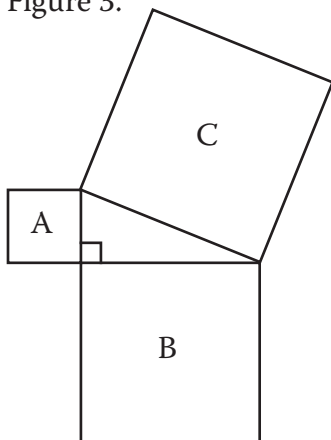

Figure 4.

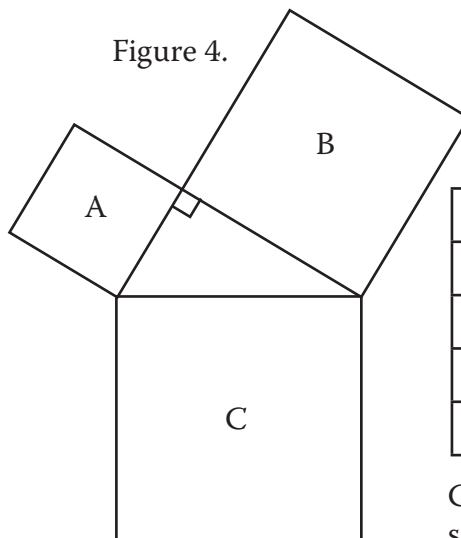

	Figure 3	Figure 4
Area of A		
Area of B		
Area of C		
Side of C		

Compare your calculations for side C by measuring the figures.

Name: _____

Date: _____

A square formed by four pegs on the geoboard is 1 unit of area.

Boundary points are pegs on the perimeter of the figure. A *boundary pair* is two boundary points.

Fill in the table for each figure below.

Figures 1 to 5.

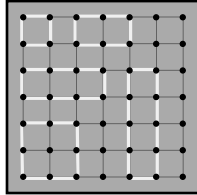

Area in Units	Number of Pegs	
	Boundary Pairs	Inside
1	2	

Figures 6 to 8.

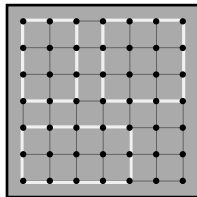

Area in Units	Number of Pegs	
	Boundary Pairs	Inside

Figures 9 to 13.

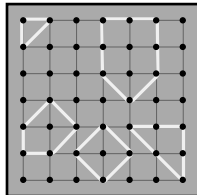

Area in Units	Number of Pegs	
	Boundary Pairs - 1	Inside

Name: _____

Date: _____

1. Are the formulas for finding the perimeter, P , and area, A , of a rectangle all correct? Write yes or no.

- _____ $P = w + h + w + h$
- _____ $P = 2w + 2h$
- _____ $P = w \times h$
- _____ $P = 2(w + h)$
- _____ $A = 2(w \cdot h)$
- _____ $A = w \times h$

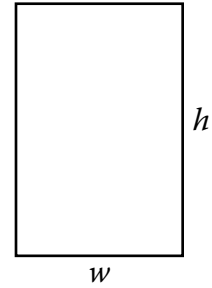

2. Are the formulas for finding the perimeter, P , and area, A , of a square all correct? Write yes or no.

- _____ $P = w + h + w + h$
- _____ $P = 2w + 2h$
- _____ $P = 2(w + h)$
- _____ $P = 4w$
- _____ $A = 2 \times (w + h)$
- _____ $A = w \cdot h$
- _____ $A = w^2$
- _____ $A = h^2$

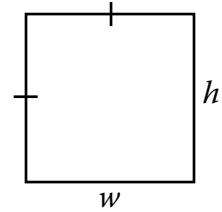

3. Are the formulas for finding the perimeter, P , and area, A , of a parallelogram all correct? Write yes or no.

- _____ $P = 2w + 2h$
- _____ $P = w \times s$
- _____ $P = 2(w + s)$
- _____ $A = 2(w \times h)$
- _____ $A = ws$
- _____ $A = wh$
- _____ $A = w \cdot h$

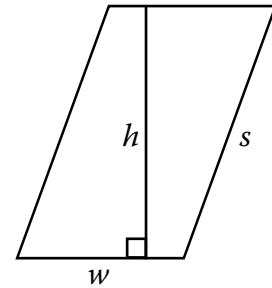

4. Are the formulas for finding the perimeter, P , and area, A , of a triangle all correct? Write yes or no.

- _____ $P = w + b + h$
- _____ $P = 2w + 2h$
- _____ $P = w + b + a$
- _____ $A = w + h$
- _____ $A = \frac{1}{2}(w \times h)$
- _____ $A = \frac{1}{2} \times (w + h)$
- _____ $A = \frac{1}{2}wh$
- _____ $A = \frac{wh}{2}$

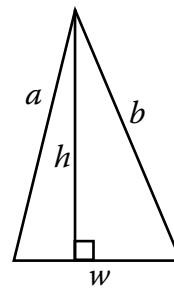

ACTIVITIES FOR TEACHING CONTINUED:

Worksheet 55, Problem 1. Tell the children to read the instructions for the first problem. Tell them the heights are drawn for them, but they need to match the correct heights and widths. The solutions are below.

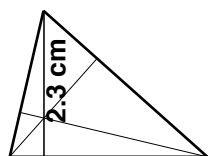

3.2 cm

$$A = \frac{1}{2}wh$$

$$A = \frac{1}{2} \times 3.2 \times 2.3$$

$$A = 3.7 \text{ cm}^2$$

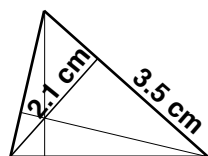

$$A = \frac{1}{2}wh$$

$$A = \frac{1}{2} \times 3.5 \times 2.1$$

$$A = 3.7 \text{ cm}^2$$

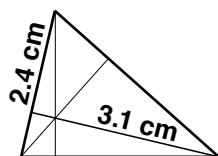

$$A = \frac{1}{2}wh$$

$$A = \frac{1}{2} \times 2.4 \times 3.0$$

$$A = 3.7 \text{ cm}^2$$

Problem 2. Tell the children to complete the second problem on the worksheet. Tell them to use the triangle to draw the perpendicular line. The solutions are below.

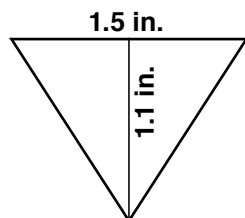

$$A = \frac{1}{2}wh$$

$$A = \frac{1}{2} \times 1.5 \times 1.1$$

$$A = 0.83 \text{ in}^2$$

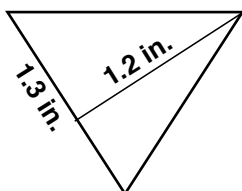

$$A = \frac{1}{2}wh$$

$$A = \frac{1}{2} \times 1.3 \times 1.2$$

$$A = 0.78 \text{ in}^2$$

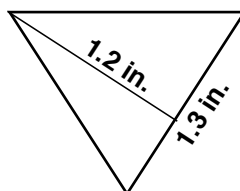

$$A = \frac{1}{2}wh$$

$$A = \frac{1}{2} \times 1.3 \times 1.2$$

$$A = 0.78 \text{ in}^2$$

Ask: What kind of a triangle is this? [isosceles acute triangle] Why do you think the answers are less accurate compared to Problem 1? [Rounding and the tenths of an inch are larger than the tenths of a centimeter.]

Problem 3. Tell the children to complete the third problem on the worksheet. Tell them that some of the sides of obtuse triangles need to be extended, which is done for them. The solutions are below.

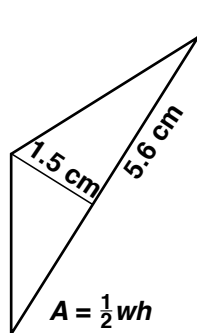

$$A = \frac{1}{2}wh$$

$$A = \frac{1}{2} \times 5.6 \times 1.5$$

$$A = 4.20 \text{ cm}^2$$

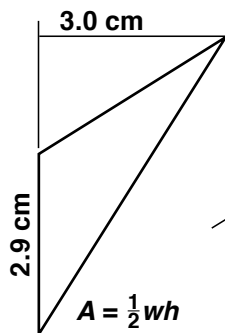

$$A = \frac{1}{2}wh$$

$$A = \frac{1}{2} \times 2.9 \times 3.0$$

$$A = 4.35 \text{ cm}^2$$

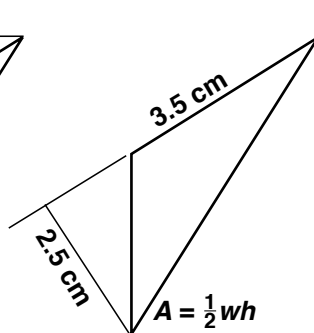

$$A = \frac{1}{2}wh$$

$$A = \frac{1}{2} \times 3.5 \times 2.5$$

$$A = 4.38 \text{ cm}^2$$

In conclusion. Ask: What do you call a perpendicular line from a side of a triangle to the opposite vertex? [height] How many heights are in a triangle? [three]

EXPLANATIONS CONTINUED:

Answers may vary slightly.

The calculated areas are not identical because the measurements are not exact. The more accurate the measurements, the closer the calculated areas will be.

If there is additional time following this lesson, play the Find the Products game, found in *Math Card Games* book, P33.

Name: _____

Date: _____

1. Find the area of the triangle below in three different ways. Measure to the nearest tenth of a centimeter.

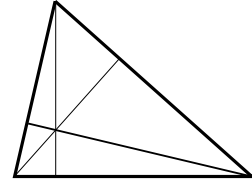
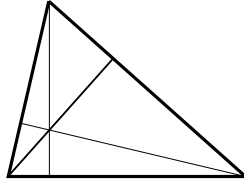
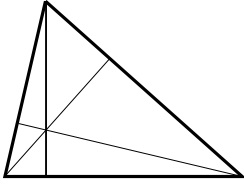

2. Find the area of the triangle below in three different ways. Measure to the nearest tenth of an inch. Calculate your answer to the nearest hundredths.

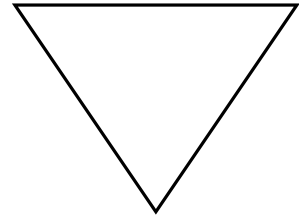
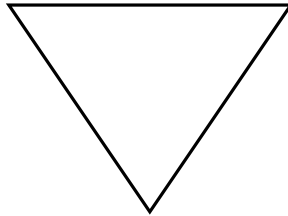
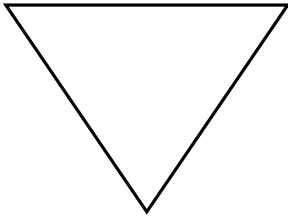

3. Find the area of the triangle below in three different ways. Measure to the nearest tenth of a centimeter. Calculate your answer to the nearest hundredths.

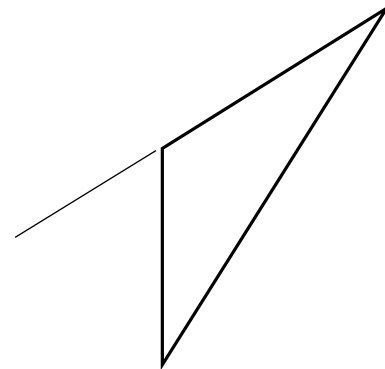
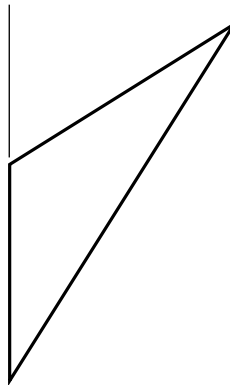
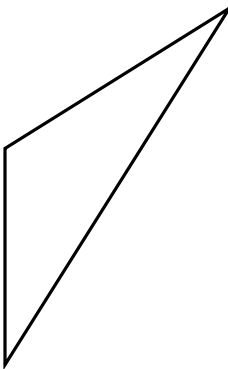

Name: _____

Date: _____

1. Find the area of the trapezoid by breaking it into two triangles as shown below. Use a tangram to draw the height for both triangles using the horizontal lines as the base.

A. Measure in centimeters.

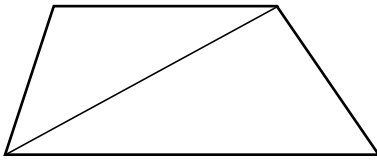

B. Write a formula for the area.

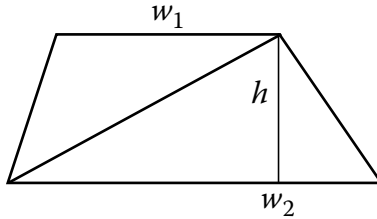

2. Find the area of the parallelogram. Then find the area of one trapezoid.

A. Measure in centimeters.

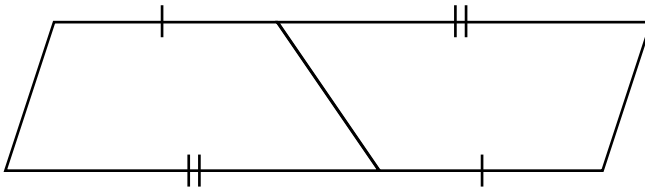

B. Write the formulas for the areas.

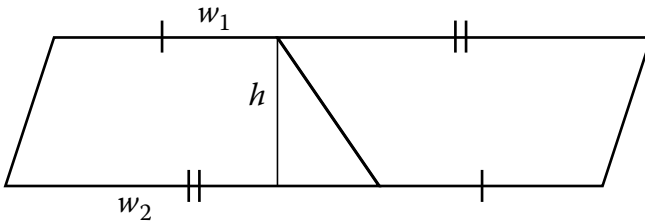

3. Find the area of the trapezoid in square centimeters by adding the areas of the parallelogram and triangle.

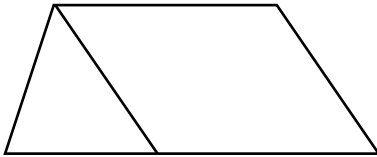

4. Find the area of the trapezoid in square centimeters using any method.

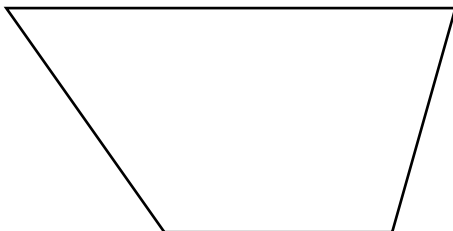

Name: _____

Date: _____

INFORMATION: The definition of an inch is: 1 in. = 2.54 cm.**Conversions you may need: 1 km (kilometer) = 1000 m 1 mi = 5280 ft 1 yd = 36 in.**

Use dimensional analysis to solve the problems. Do not round. You may use a calculator.

1. Find how many centimeters are in a foot.

_____ → _____ → _____

$$1 \text{ ft} = 1 \text{ ft} \times \frac{\quad}{\text{ft}} \times \frac{\quad}{\text{in.}} = \underline{\hspace{2cm}}$$
 Does your answer agree with a ruler? _____

2. Find how many centimeters are in a yard.

_____ → ft → _____ → _____

$$1 \text{ yd} = \underline{\hspace{2cm}} \times \underline{\hspace{2cm}} \times \underline{\hspace{2cm}} \times \underline{\hspace{2cm}} = \underline{\hspace{2cm}}$$

Does your answer agree with a yardstick? _____

3. Find how many kilometers are in a mile.

_____ → ft → _____ → cm → m → km

$$1 \text{ mi} = \underline{\hspace{2cm}} \times \underline{\hspace{2cm}} \times \underline{\hspace{2cm}} \times \underline{\hspace{2cm}} \times \underline{\hspace{2cm}} \times \underline{\hspace{2cm}} = \underline{\hspace{2cm}}$$

Which is longer, a kilometer or a mile? _____

Round your answer to one decimal point. _____

4. How many miles are in a kilometer? Use your unrounded answer from Problem 3.

Round to two decimal places.

_____ → _____

Name: _____ Date: _____

Write the following terms in the chart: no name, trapezoid, parallelogram, rhombus, kite, quadrilateral, square, and rectangle. Use your drawing tools to draw a sample figure in each of the six boxes. Then answer the questions below.

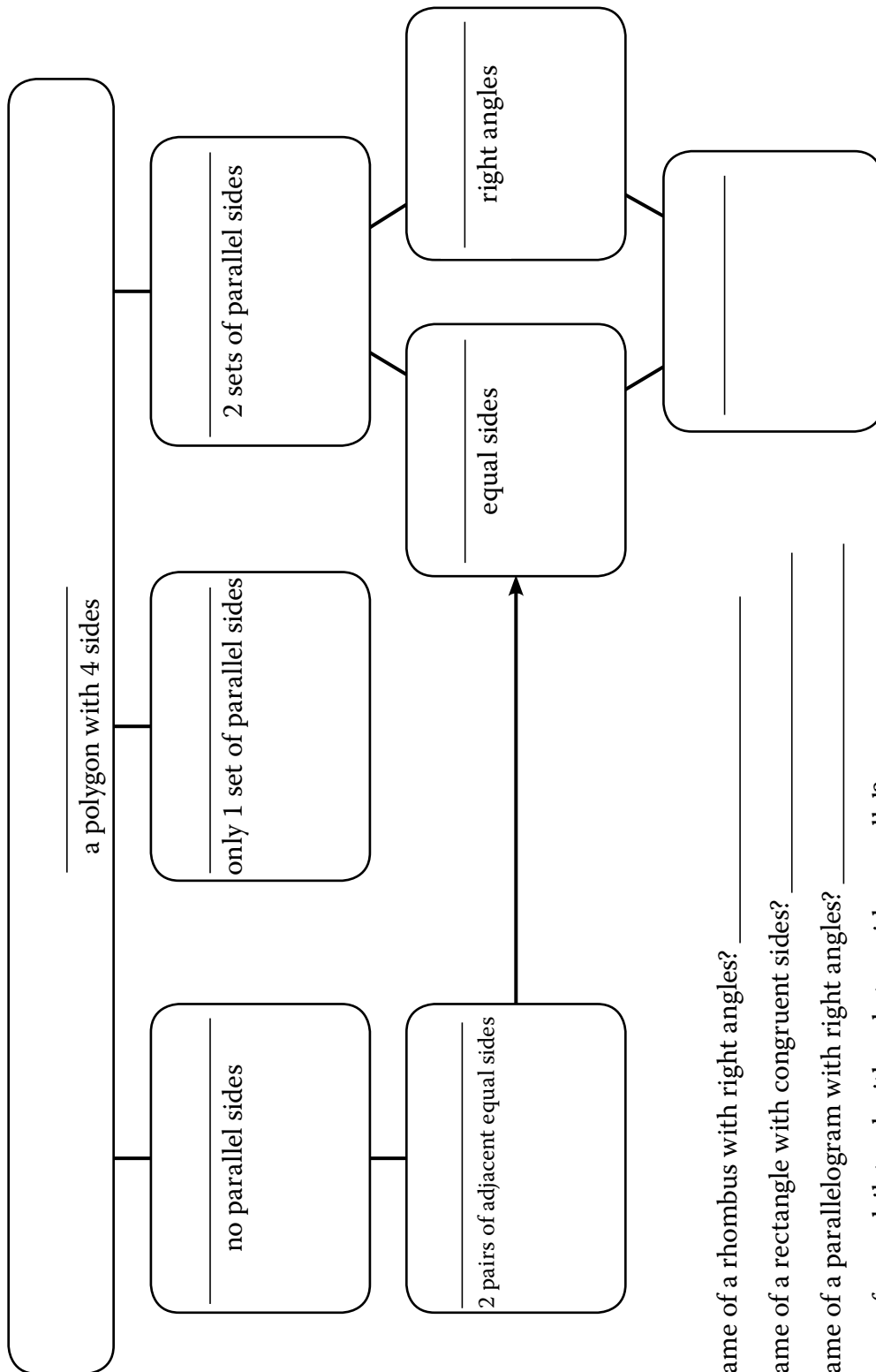

What is the name of a rhombus with right angles? _____

What is the name of a rectangle with congruent sides? _____

What is the name of a parallelogram with right angles? _____

What is the name of a quadrilateral with only two sides parallel? _____

What three quadrilaterals can be made with these lines: $\parallel \parallel \parallel$ _____

SLIDE N' MEASURE COMPASS

NEW effective August 2025; used in RightStart Mathematics Levels E, F, G, and H

** measures in inches and centimeters **

The Slide N' Measure Compass will draw circles with radii from 1.3 to 12 cm and 1/2 inch to 4-11/16 inches.

Align the center of the circle part of the compass with the center mark of your circle and hold it with your non-writing hand. Place the radius arm to the left. See the first figure on the right.

Position the slide to point to the desired radius. Put your pencil in the hole for that radius, then draw the circle in a clockwise direction. If you are left-handed, start the radius arm on the right side and draw the circle counterclockwise.

When your circle is almost complete, raise the heel of your hand, and continue drawing the circle until you have completed it. See the second figure.

To make more accurate circles, keep your pencil perpendicular to the paper. Also, keep light pressure against the outside of the hole while drawing.

A demonstration on using the Slide N' Measure Compass can be found at RightStartMath.com/geometry.

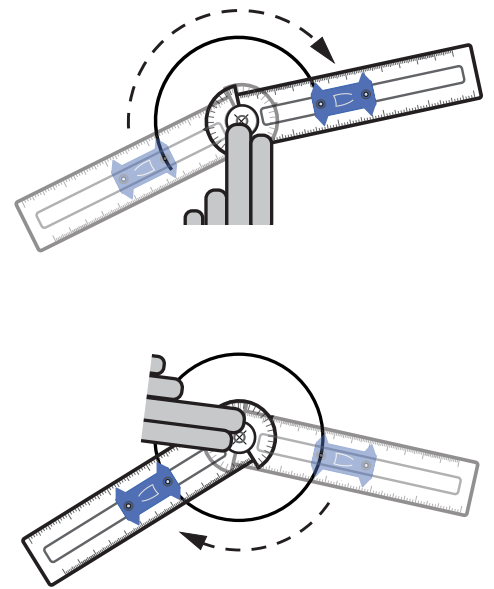

8/25

SAFE-T COMPASS®

used prior to September 2025 in Levels E and F

** measures in inches **

Start by aligning the center of the white rotator over the center of the circle being drawn and hold it with your non-writing hand. Find the hole marked with the desired radius measurement and insert the pencil.

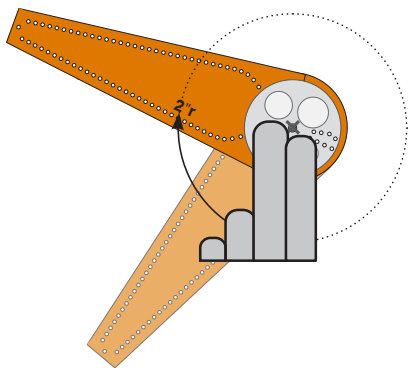

Keep the white rotator still and move the radius arm in an arc to draw the circle.

mmARC COMPASS

used prior to August 2025 in Levels G and H

** measures in millimeters **

Align the center of the movable part of the compass, the rotator, with the center of your circle and hold it with your non-writing hand. Place the radius arm to the left.

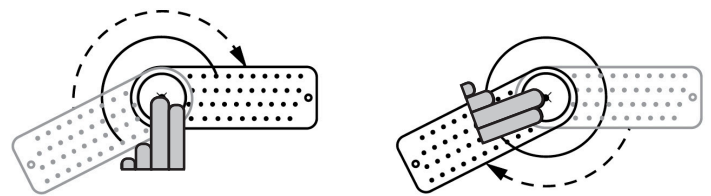

Put the pencil in the hole for the desired radius, then draw the circle in a clockwise direction. When the circle is almost complete, raise the heel of the hand. See the second figure above.

If you are left-handed, start on the right side and draw the circle counterclockwise.

To make more accurate circles, keep your pencil perpendicular to the paper. Also, press against the outside of the hole while drawing.

A demonstration on using this compass can be found at RightStartMath.com/geometry.

MULTIPLICATION TABLE

1	2	3	4	5	6	7	8	9	10
2	4	6	8	10	12	14	16	18	20
3	6	9	12	15	18	21	24	27	30
4	8	12	16	20	24	28	32	36	40
5	10	15	20	25	30	35	40	45	50
6	12	18	24	30	36	42	48	54	60
7	14	21	28	35	42	49	56	63	70
8	16	24	32	40	48	56	64	72	80
9	18	27	36	45	54	63	72	81	90
10	20	30	40	50	60	70	80	90	100